

## ROBOTIC PALLETIZING CELL (AR-200) AUTO BAG ALIGNMENT GUIDE

This Engineering Bulletin presents the latest improvements to the AR-200 Robotic Palletizing Cell. The changeover is now automatic (no mechanical adjustments) when combining the optional bag width adjustment system on the finger gripper and motorized guides on the alignment conveyor.

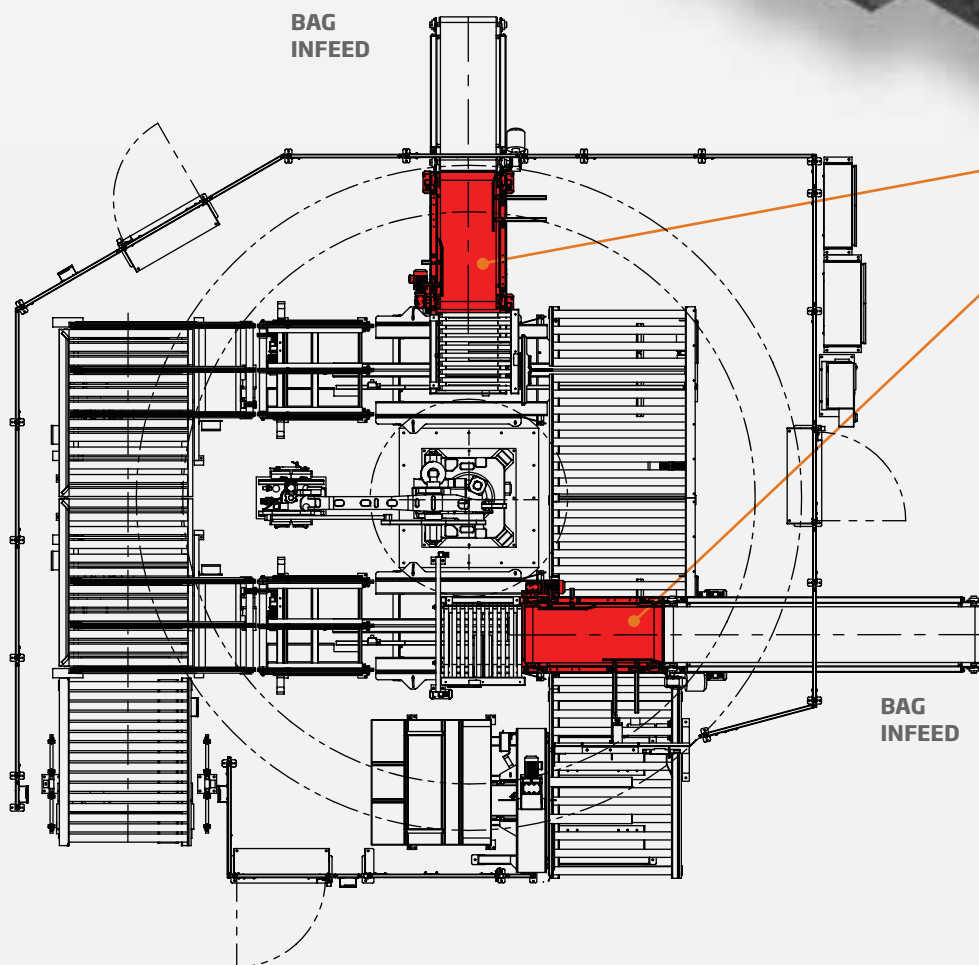
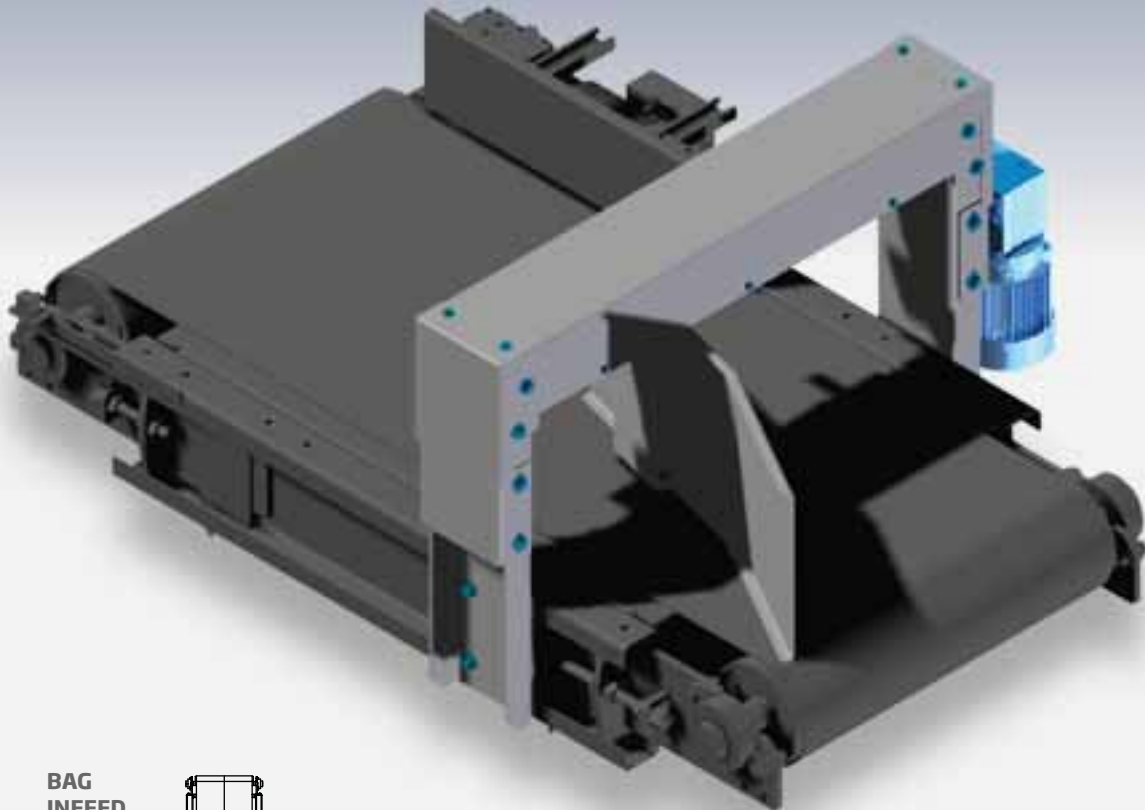

Alignment conveyor

### THE ALIGNMENT GUIDE ALLOWS FOR :

- Easier to operation
- Safer: no need to enter the cell for adjustments
- Shorter changeovers delays
- Consistant and precise adjustments resulting in improved pallet stability and appearance

If you wish to improve your equipment, we will gladly answer your questions and provide you with a quotation.